

vivitek[®] User Manual
Vivid Color, Vivid Life

HK2288

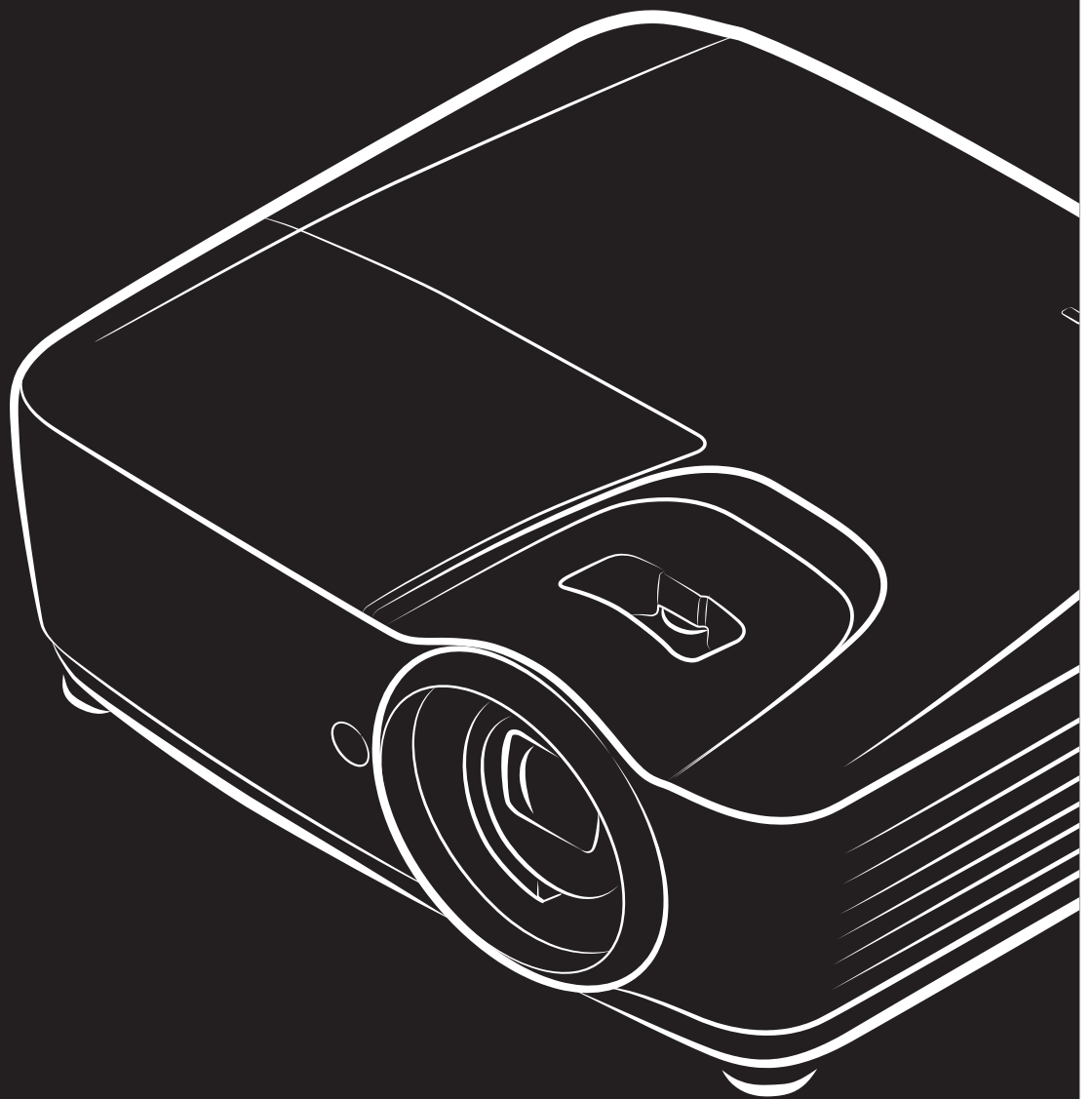

DLP[®]
TEXAS INSTRUMENTS

4K
ULTRA HD

Copyright

This publication, including all photographs, illustrations and software, is protected under international copyright laws, with all rights reserved. Neither this manual, nor any of the material contained herein, may be reproduced without written consent of the author.

© Copyright 2017

Disclaimer

The information in this document is subject to change without notice. The manufacturer makes no representations or warranties with respect to the contents hereof and specifically disclaims any implied warranties of merchantability or fitness for any particular purpose. The manufacturer reserves the right to revise this publication and to make changes from time to time in the content hereof without obligation of the manufacturer to notify any person of such revision or changes.

Trademark Recognition



Kensington is a U.S. registered trademark of ACCO Brand Corporation with issued registrations and pending applications in other countries throughout the world.



HDMI, the HDMI Logo, and High-Definition Multimedia Interface are trademarks or registered trademarks of HDMI Licensing LLC in the United States and other countries.

All other product names used in this manual are the properties of their respective owners and are acknowledged.

Important Safety Information



Important:

*It is strongly recommended that you read this section carefully before using the projector. These safety and usage instructions will ensure that you enjoy many years of safe use of the projector. **Keep this manual for future reference.***

Symbols Used

Warning symbols are used on the unit and in this manual to alert you of hazardous situations.

The following styles are used in this manual to alert you to important information.

Note:

Provides additional information on the topic at hand.



Important:

Provides additional information that should not be overlooked.



Caution:

Alerts you to situations that may damage the unit.



Warning:

Alerts you to situations that may damage the unit, create a hazardous environment, or cause personal injury.

Throughout this manual, component parts and items in the OSD menus are denoted in bold font as in this example:

“Push the **Menu** button on the remote control to open the **Main** menu.”

General Safety Information

- Do not open the unit case. Aside from the projection lamp, there are no user-serviceable parts in the unit. For servicing, contact qualified service personnel.
- Follow all warnings and cautions in this manual and on the unit case.
- The projection lamp is extremely bright by design. To avoid damage to eyes, do not look into the lens when the lamp is on.
- Do not place the unit on an unstable surface, cart, or stand.
- Avoid using the system near water, in direct sunlight, or near a heating device.
- Do not place heavy objects such as books or bags on the unit.

Note:

As with any bright light source, do not stare into the beam, RG2 IEC 62471-5:2015

Projector Installation Notice

- Place the projector in a horizontal position
The tilt angle of the projector should not exceed 15 degrees, nor should the projector be installed in any way other than the desktop and ceiling mount, otherwise lamp life could decrease dramatically, and may lead to other **unpredictable damages**.

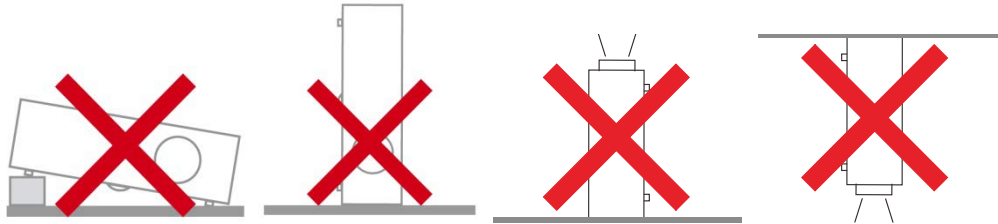
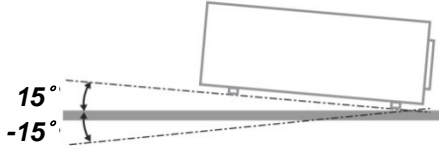

- Allow at least 50 cm clearance around the exhaust vent.

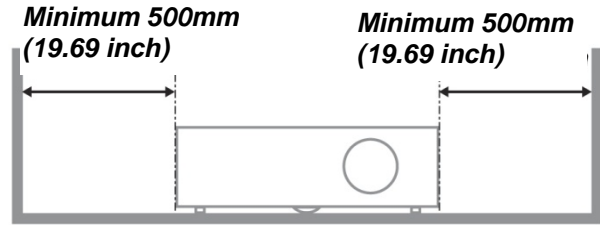
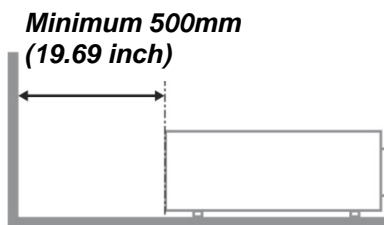

-

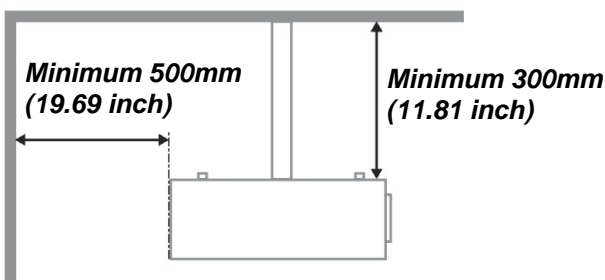
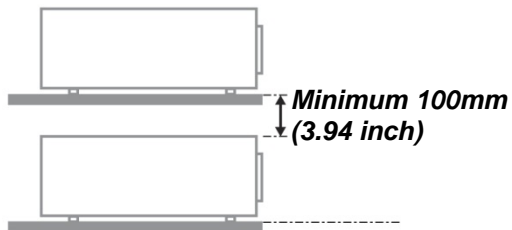
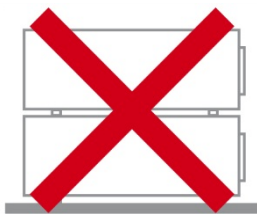

- Ensure that the intake vents do not recycle hot air from the exhaust vent.
- When operating the projector in an enclosed space, ensure that the surrounding air temperature within the enclosure does not exceed operation temperature while the projector is running, and the air intake and exhaust vents are unobstructed.
- All enclosures should pass a certified thermal evaluation to ensure that the projector does not recycle exhaust air, as this may cause the device to shutdown even if the enclosure temperature is within the acceptable operation temperature range.

Verify Installation Location

- To supply power, the 3-blade (with earthing lead) socket should be used to ensure proper grounding and equalized ground potential for all of the equipment in the Projector System.
- The power code provided with the Projector should be used. In case of any missing item, other qualified 3-blade (with earthing lead) power cord can be used as substitution; however, do not use 2-blade power cord.
- Verify if the voltage is stable, grounded properly and there is no electricity leakage.
- Measure total power consumption which should not higher the safety capacity and avoid safety issue and short circuit.
- Turn on Altitude Mode when located in high altitude areas
- The projector can only be installed upright or inverted.
- When installation the bracket, make sure the weight limit is not exceed and firmly secured.
- Avoid installing near air conditioner duct or subwoofer.
- Avoid installing at high temperature, insufficient cooling and heavy dust locations.
- Keep your product away from fluorescent lamps (> 1 meter) to avoid malfunction caused by IR interference
- Install the projector above 200cm to avoid damage.
- The power cord and signal cable should be connected before power on the projector. During the projector starting and operating process, DO NOT insert or remove the signal cable or the power cord to avoid damaging the projector.

Cooling notes

Air outlet

- Make sure the air outlet is 50cm clear of any obstruction to ensure proper cooling.
- Air outlet location should not be in front of the lens of other projector to avoid causing illusions.
- Keep the outlet at least 100cm away from the inlets of other projectors
- The projector generates a massive amount of heat during use. The internal fan dissipates the heat of the projector when shutting down, and such process may continue for a certain period. After the project enters STANDBY MODE status, press the AC power button to turn off the projector and remove the power cord. DO NOT remove the power cord during the shutdown process, as it may cause damage to the projector. In the meantime, the delayed heat radiating will also affect the service life of the projector. The shutdown process may vary depending on the model used. Whatever the case may be, be sure to disconnect the power cord till after the projector enters the STANDBY status.

Air inlet

- Make sure there is no object blocking air input within 30 cm.
- Keep the inlet away from other heat sources
- Avoided heavy dust area

Power Safety

- Only use the supplied power cord.
- Do not place anything on the power cord. Place the power cord where it will not be in the way of foot traffic.
- Remove the batteries from the remote control when storing or not in use for a prolonged period.

Replacing the Lamp

Replacing the lamp can be hazardous if done incorrectly. See [Replacing the Projection Lamp](#) on page 28 for clear and safe instructions for this procedure. Before replacing the lamp:

- Unplug the power cord.
- Allow the lamp to cool for about one hour.

**Caution:**

In rare cases the lamp bulb may burn out during normal operation and cause glass dust or shards to be discharged outward from the rear exhaust vent.

Do not inhale or do not touch glass dust or shards. Doing so could result in injury.

Always keep your face away from the exhaust vent so that you do not suffer from the gas and broken shards of the lamp.

Cleaning the Projector

- Unplug the power cord before cleaning. See [Cleaning the Projector](#) page 32.
- Allow the lamp to cool for about one hour.

Regulatory Warnings

Before installing and using the projector, read the regulatory notices in the [Regulatory Compliance](#) on page 43.

Important Recycle Instructions:



Lamp(s) inside this product contain mercury. This product may contain other electronic waste that can be hazardous if not disposed of properly. Recycle or dispose in accordance with local, state, or federal Laws. For more information, contact the Electronic Industries Alliance at WWW.EIAE.ORG. For lamp specific disposal information check WWW.LAMPRECYCLE.ORG.

Symbol Explanations



DISPOSAL: Do not use household or municipal waste collection services for disposal of electrical and electronic equipment. EU countries require the use of separate recycling collection services.

Main Features

- *Ultra HD 4K (3840 x 2160) resolution for outstanding details and stunning visuals*
- *DLP® DarkChip3™ and BrilliantColor™ technologies for optimal black levels and vibrant colorful images*
- *2000 ANSI lumens for an amazing brightness*
- *Advanced video processor for fluid video streaming and 12-bit programmable RGB colour adjustments*
- *High Dynamic Range (HDR10) for enriched brightness and impeccable vibrancy for precise natural colors*
- *REC 709 for an incredible cinematic like movie experience*
- *Six segment RGBRGB color wheel delivers outstanding reds, greens and blue color reproductions*
- *Fine tune and optimize an image with advanced calibrations, including gamma and color management settings*
- *Advanced HDMI 2.0 (x3) connectors for high quality digital video signals and quick data transfer rates*
- *Audio ready with built-in 10 watt speaker and audio out port*
- *Long lasting energy efficient lamps that last up to 4000 hours*
- *Wide 1.5x zoom range and vertical lens shift for greater installation convenience and flexibility*
- *Full functioning remote control and intuitive 9 key menu pad for easy control*
- *Dual infrared sensors for handy remote control from either in front or behind the projector*
- *Anti-theft security features include: Kensington® security slot, security bar, and PIN lock keypad*

About this Manual

This manual is intended for end users and describes how to install and operate the DLP projector. Wherever possible, relevant information—such as an illustration and its description—has been kept on one page. This printer-friendly format is both for your convenience and to help save paper, thereby protecting the environment. It is suggested that you only print sections that are relevant to your needs.

Table of Contents

GETTING STARTED.....	1
PACKING CHECKLIST	1
VIEWS OF PROJECTOR PARTS.....	2
<i>Front-right View</i>	2
<i>Rear view</i>	3
<i>Rear view—On-screen Display (OSD) buttons</i>	4
<i>Bottom view</i>	5
REMOTE CONTROL PARTS	6
REMOTE CONTROL OPERATING RANGE	8
PROJECTOR AND REMOTE CONTROL BUTTONS.....	8
INSERTING THE REMOTE CONTROL BATTERIES	9
SETUP AND OPERATION.....	10
STARTING AND SHUTTING DOWN THE PROJECTOR	10
ADJUSTING THE PROJECTOR LEVEL	12
ADJUSTING THE VERTICAL IMAGE POSITION	13
ADJUSTING THE ZOOM AND FOCUS.....	13
ADJUSTING THE VOLUME	14
ON-SCREEN DISPLAY (OSD) MENU SETTINGS.....	15
OSD MENU CONTROLS	15
<i>Navigating the OSD</i>	15
SETTING THE OSD LANGUAGE.....	16
OSD MENU OVERVIEW.....	17
MAIN MENU.....	19
IMAGE SETTINGS	20
COLOR SETTINGS.....	21
<i>HSG Adjustment</i>	22
LAMP CONTROL.....	23
SETUP	24
<i>Menu Settings</i>	25
ADVANCED.....	26
INFORMATION MENU	27
MAINTENANCE AND SECURITY	28
REPLACING THE PROJECTION LAMP	28
<i>Resetting the Lamp</i>	31
CLEANING THE PROJECTOR	32
<i>Cleaning the Lens</i>	32
<i>Cleaning the Case</i>	32
USING THE PHYSICAL LOCK	33
<i>Using the Security Bar</i>	33
TROUBLESHOOTING.....	34
COMMON PROBLEMS AND SOLUTIONS	34
TIPS FOR TROUBLESHOOTING	34
LED ERROR MESSAGES	35
IMAGE PROBLEMS	35
LAMP PROBLEMS.....	36
REMOTE CONTROL PROBLEMS.....	36
AUDIO PROBLEMS	36
HAVING THE PROJECTOR SERVICED	36
HDMI Q & A	37
SPECIFICATIONS.....	38
SPECIFICATIONS.....	38
PROJECTION DISTANCE VS. PROJECTION SIZE	39
<i>Projection Distance and Size Table</i>	39

TIMING MODE TABLE40
PROJECTOR DIMENSIONS42
REGULATORY COMPLIANCE..... 43
FCC WARNING43
CANADA.....43
SAFETY CERTIFICATIONS43
APPENDIX I..... 44
OP COMMAND.....44

GETTING STARTED

Packing Checklist

Carefully unpack the projector and check that the following items are included:

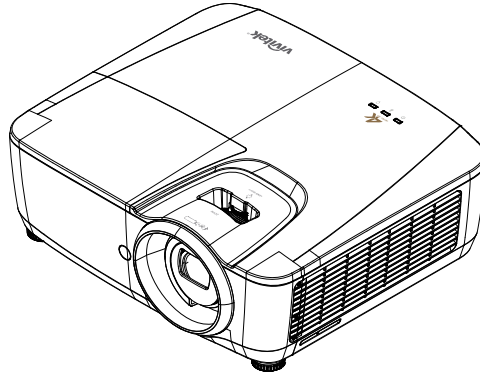

DLP PROJECTOR



*REMOTE CONTROL
(WITH TWO AAA BATTERIES)*

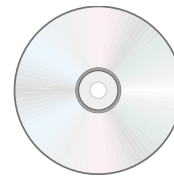

*CD-ROM
(THIS USER'S MANUAL)*

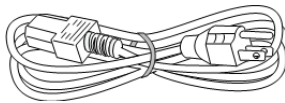

POWER CORD

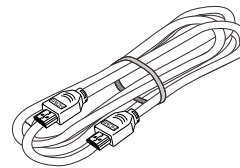

HDMI CABLE

Contact your dealer immediately if any items are missing, appear damaged, or if the unit does not work. It is recommended that you keep the original packing material should you ever need to return the equipment for warranty service.



Caution:

Avoid using the projector in dusty environments.

Views of Projector Parts

Front-right View

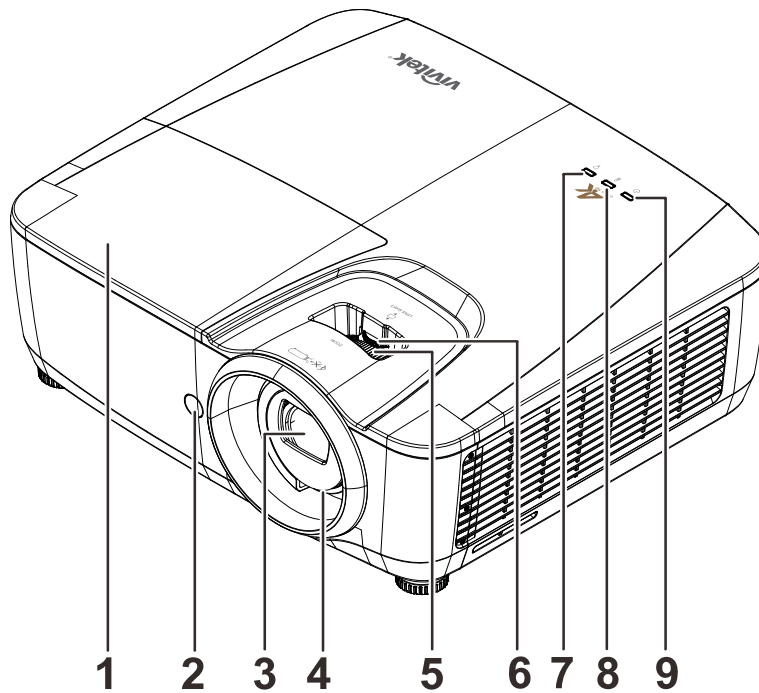

ITEM	LABEL	DESCRIPTION		SEE PAGE
1.	Lamp cover	Removes cover to replace lamp module.		
2.	IR receiver	Receive IR signal from remote control.		
3.	Lens	Projection Lens.		
4.	Focus ring	Focuses the projected image.		13
5.	Zoom ring	Enlarges the projected image.		
6.	LENS SHIFT	For Image vertical shift adjustment.		13
7.	LAMP LED	Flashing	Error code	35
8.	TEMP LED	Red	Over Temperature, T1 error	
9.	POWER LED	Green	Ready to power on (Standby)	
		Flashing	Start warm up, Cooling, Error code	



Important:

Ventilation openings on the projector allow for good air circulation, which keeps the projector lamp cool. Do not obstruct any of the ventilation openings.

Rear view

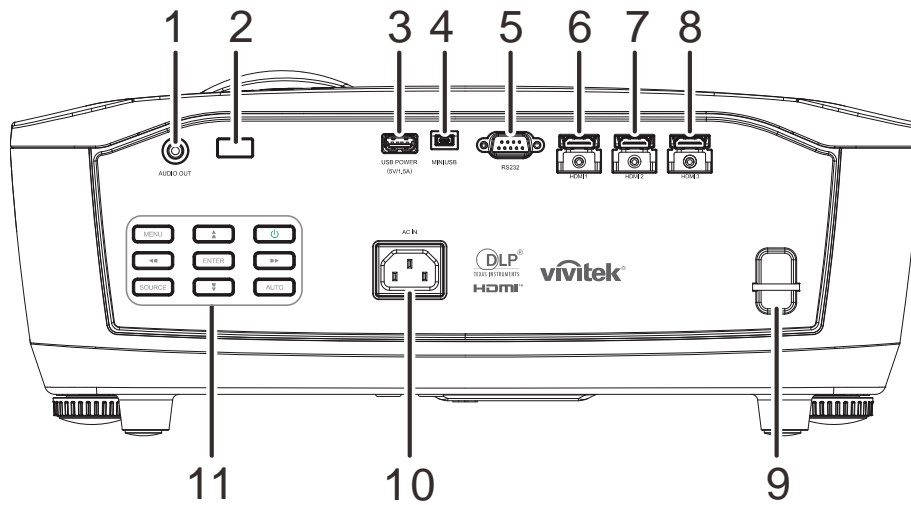

ITEM	LABEL	DESCRIPTION	SEE PAGE
1.	AUDIO OUT	Connect an AUDIO cable to an audio amplifier.	
2.	IR receiver	Receive IR signal from remote control.	
3.	USB POWER (5V/1.5A)	Connect the USB cable for power supply.	
4.	MINI USB	Connect the USB cable from a computer.	
5.	RS-232C	Connect RS-232 serial port cable for remote control.	
6.	HDMI 1	Connect the HDMI cable from a HDMI device.	
7.	HDMI 2	Connect the HDMI cable from a HDMI device.	
8.	HDMI 3	Connect the HDMI cable from a HDMI device.	
9.	Security Bar	For security and authorized usage.	33
10.	AC IN	Connect the POWER cable.	10
11.	Function keys	See Rear view—On-screen Display (OSD) buttons.	4



Warning:

As a safety precaution, disconnect all power to the projector and connecting devices before making connections.

Rear view—On-screen Display (OSD) buttons

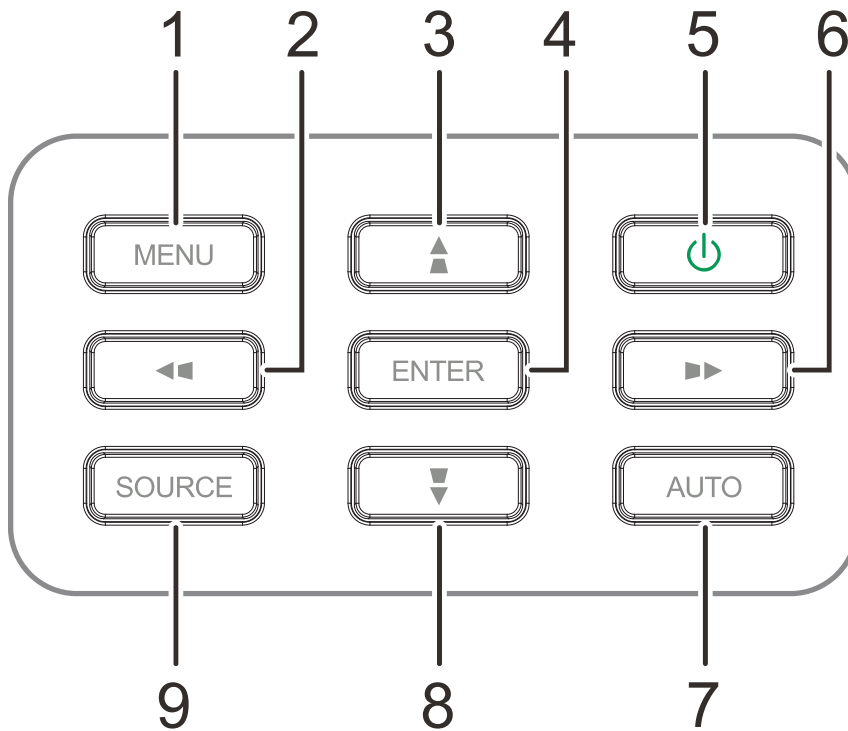

ITEM	LABEL	DESCRIPTION	SEE PAGE
1.	MENU	Opens and exits OSD menus	15
2.	◀◀	Navigates and changes settings in the OSD	
3.	▲ ▲	Navigates in the OSD	
4.	ENTER	Enter or confirm highlighted OSD menu item	
5.	⏻	Turns the projector On or Off	
6.	▶▶	Navigates and changes settings in the OSD	
7.	AUTO	Optimizes image size, position, and resolution	
8.	▼ ▼	Navigates in the OSD	
9.	SOURCE	Enter the Source menu	

Note:

Keystone (▲ / ▼ / ◀ / ▶) function is unavailable in this model.

Bottom view

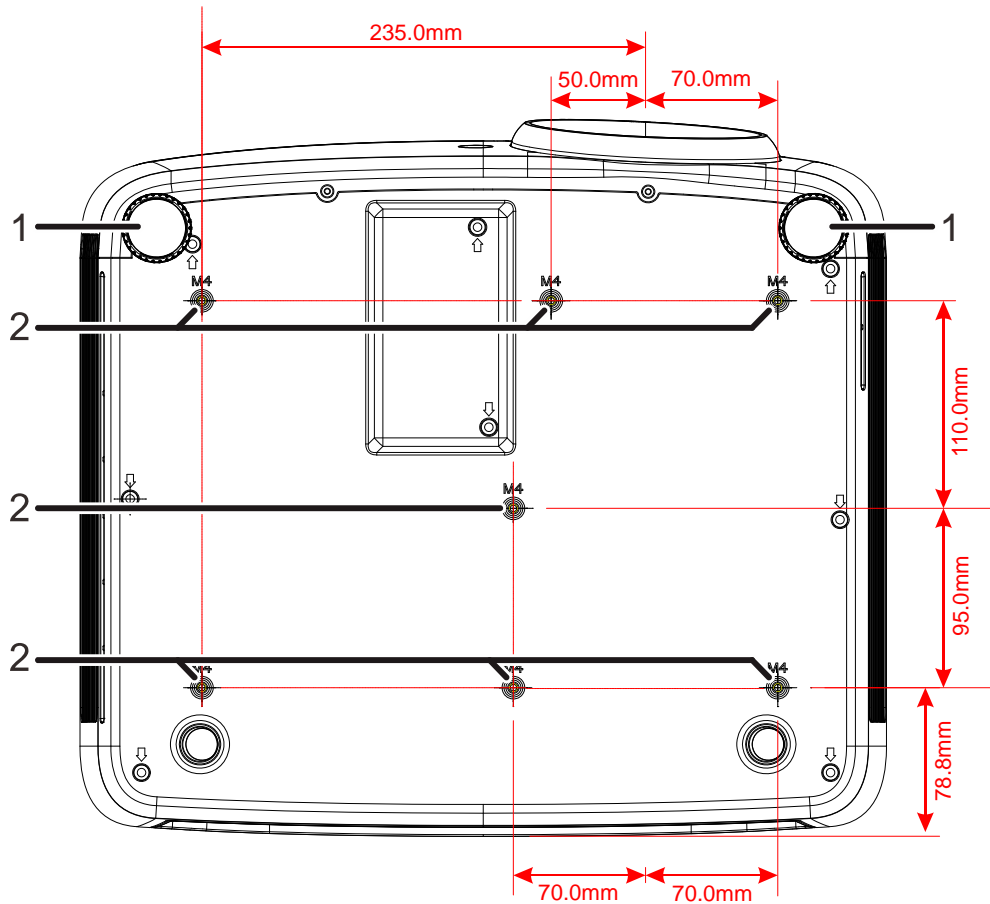

ITEM	LABEL	DESCRIPTION	SEE PAGE
1.	Tilt adjustor	Rotate adjuster lever to adjust angle position.	12
2.	Ceiling support holes	Contact your dealer for information on mounting the projector on a ceiling	

Note:

When installing, ensure that you use only UL Listed ceiling mounts.

For ceiling installations, use approved mounting hardware and M4 screws with a maximum screw depth of 8 mm (0.31 inch).

The construction of the ceiling mount must be of a suitable shape and strength. The ceiling mount load capacity must exceed the weight of the installed equipment, and as an additional precaution be capable of withstanding three times the weight of the equipment over a period of 60 seconds.

Remote Control Parts

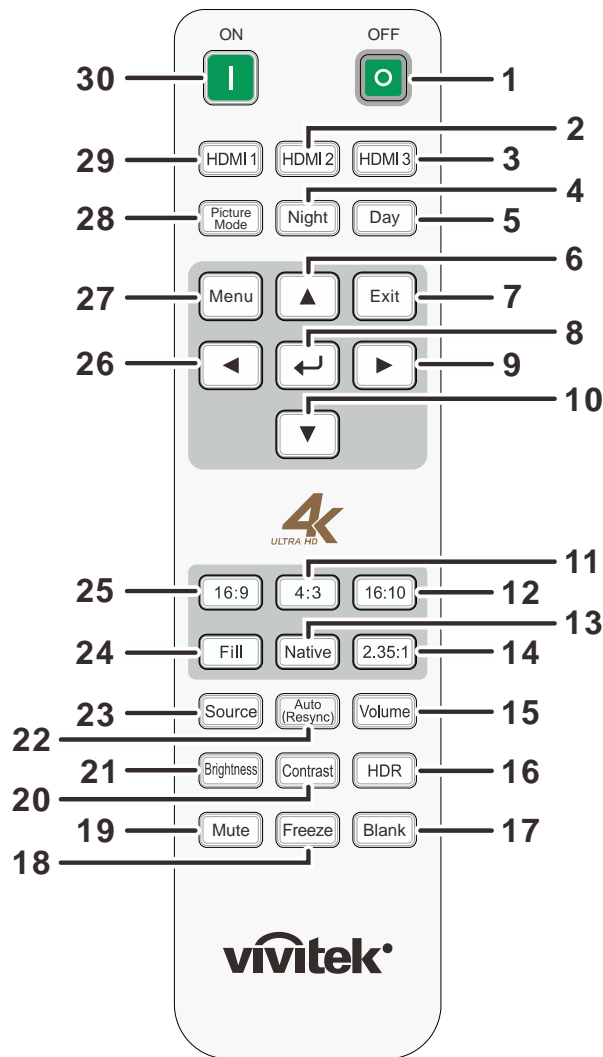

Important:

1. Avoid using the projector with bright fluorescent lighting turned on. Certain high-frequency fluorescent lights can disrupt remote control operation.
2. Be sure nothing obstructs the path between the remote control and the projector. If the path between the remote control and the projector is obstructed, you can bounce the signal off certain reflective surfaces such as projector screens.
3. The buttons and keys on the projector have the same functions as the corresponding buttons on the remote control. This user's manual describes the functions based on the remote control.

ITEM	LABEL	DESCRIPTION	SEE PAGE
1.	OFF	Turns the projector off.	15
2.	HDMI 2	Toggles the input sources for display between HDMI sources.	
3.	HDMI 3	Toggles the input sources for display between HDMI sources.	
4.	Night	Switch the picture mode to Night mode.	
5.	Day	Switch the picture mode to Day mode.	
6.	▲	Navigates and changes settings in the OSD.	15
7.	EXIT	Goes back to previous OSD menu, exits and saves menu settings.	
8.	↩	Enters and confirms settings in the OSD.	15
9.	▶	Navigates and changes settings in the OSD.	
10.	▼	Navigates and changes settings in the OSD.	
11.	4 : 3	Displays 4 : 3 aspect ratio.	
12.	16 : 10	Displays 16 : 10 aspect ratio.	
13.	Native	Displays Native aspect ratio.	
14.	2.35 : 1	Displays 2.35 : 1 aspect ratio.	
15.	Volume	Displays the volume setting bar.	14
16.	HDR	Turns on the HDR mode.	
17.	Blank	Toggles the screen between blank and normal.	
18.	Freeze	Freeze/unfreezes the on-screen picture.	
19.	Mute	Toggles the built-in speaker between on and off.	14
20.	Contrast	Displays the contrast setting bar.	
21.	Brightness	Displays the brightness setting bar.	
22.	Auto (Resync)	Switch again to resync current source.	15
23.	Source	Displays the source selection bar.	
24.	Fill	Displays Fill aspect ratio.	
25.	16 : 9	Displays 16 : 9 aspect ratio.	
26.	◀	Navigates and changes settings in the OSD.	15
27.	Menu	Opens the OSD.	
28.	Picture Mode	Navigates and switches to each picture mode settings.	
29.	HDMI1	Toggles the input sources for display between HDMI sources.	
30.	ON	Turns the projector on.	15

Remote Control Operating Range

The remote control uses infrared transmission to control the projector. It is not necessary to point the remote directly at the projector. Provided you are not holding the remote perpendicular to the sides or the rear of the projector, the remote will function well within a radius of about 7 meters (23 feet) and 15 degrees above or below the projector level. If the projector does not respond to the remote control, move a little closer.

Projector and Remote Control Buttons

The projector can be operated using the remote control or the buttons on the projector. All operations can be carried out with the remote control; however, the buttons on the projector are limited in use.

Inserting the Remote Control Batteries

1. Remove the battery compartment cover by sliding the cover in the direction of the arrow.

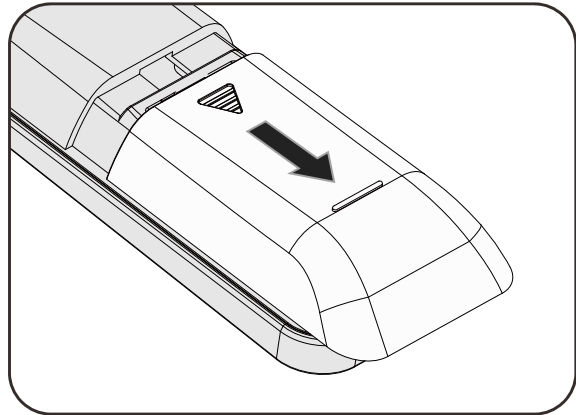

2. Insert the battery with the positive side facing up.

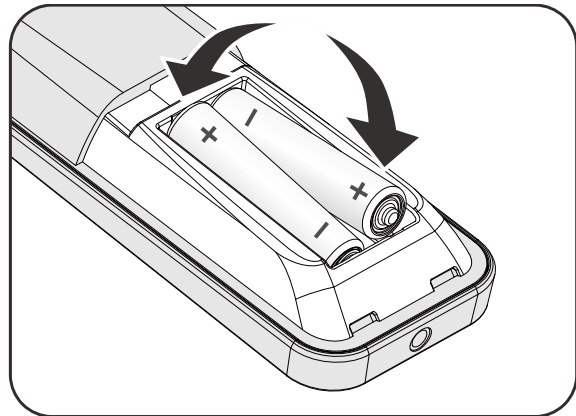

3. Replace the cover.

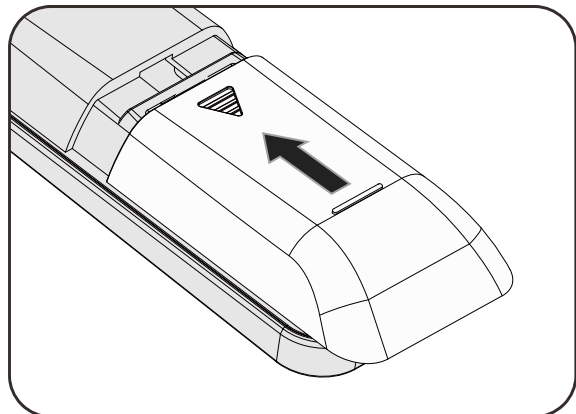

Caution:

1. Only use AAA batteries (Alkaline batteries are recommended).
2. Dispose of used batteries according to local ordinance regulations.
3. Remove the batteries when not using the projector for prolonged periods.
4. RISK OF EXPLOSION IF BATTERY IS REPLACED BY AN INCORRECT TYPE.
5. DISPOSE OF USED BATTERIES ACCORDING TO THE INSTRUCTIONS.

SETUP AND OPERATION

Starting and Shutting down the Projector

1. Connect the power cord to the projector. Connect the other end to a wall outlet.

The  **POWER** LED on the projector light.

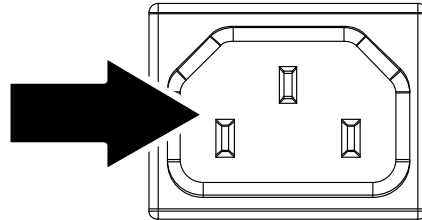



2. Turn on the connected devices.

3. Ensure the POWER LED not a flashing. Then press the  **POWER** button to turn on the projector.

The projector splash screen displays and connected devices are detected.



4. If more than one input device is connected, press the **SOURCE** button and use   to scroll among devices.

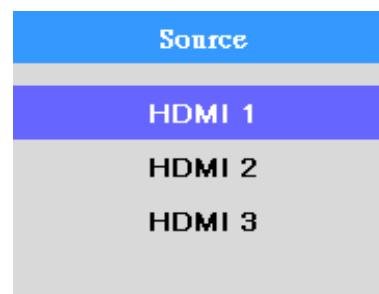

- HDMI 1: High-Definition Multimedia Interface.
- HDMI 2: High-Definition Multimedia Interface.
- HDMI 3: High-Definition Multimedia Interface.

5. When the “Power Off? / Press **Power** again” message appears, press the **POWER** button. The projector turns off.

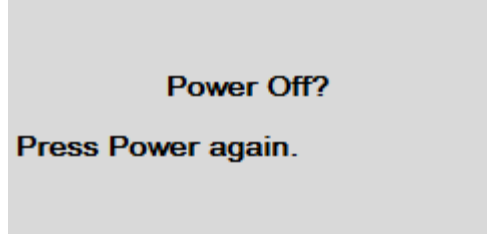

Power Off?
Press Power again.



Caution:

Do not unplug the power cord until the power LED stops flashing—indicating the projector has cooled down.

Adjusting the Projector Level

Take note of the following when setting up the projector:

- *The projector table or stand should be level and sturdy.*
- *Position the projector so that it is perpendicular to the screen.*
- *Ensure the cables are in a safe location. You could trip over them.*

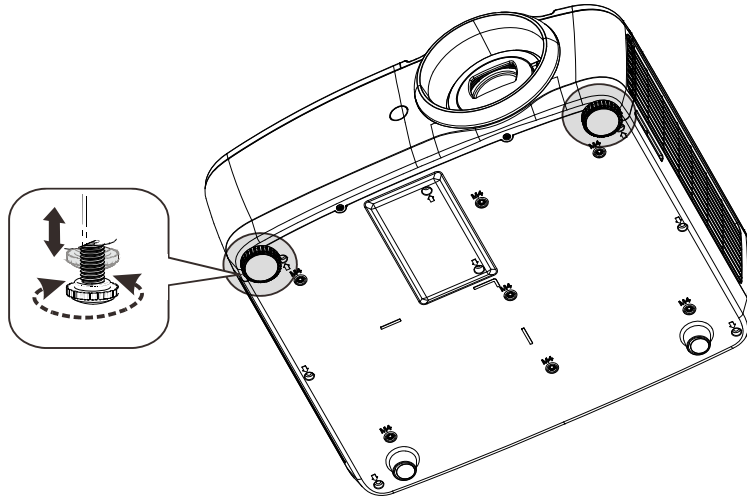

To adjust the angle of the picture, turn the tilt-adjuster right or left until the desired angle has been achieved.

Adjusting the vertical image position

The Lens Shift function can be used to adjust the position of the vertically.

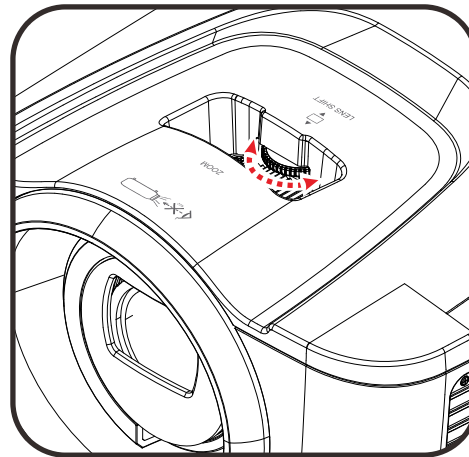

The display position can be shifted upward up to 15% and down to 10% elevation of the display.

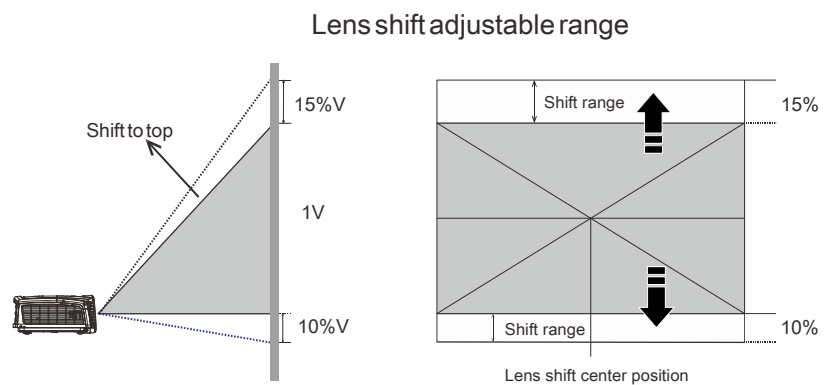

Adjusting the Zoom and Focus

1. Use the **Image-zoom** control (on the projector only) to resize the projected image and screen size **B**.
2. Use the **Image-focus** control (on the projector only) to sharpen the projected image **A**.

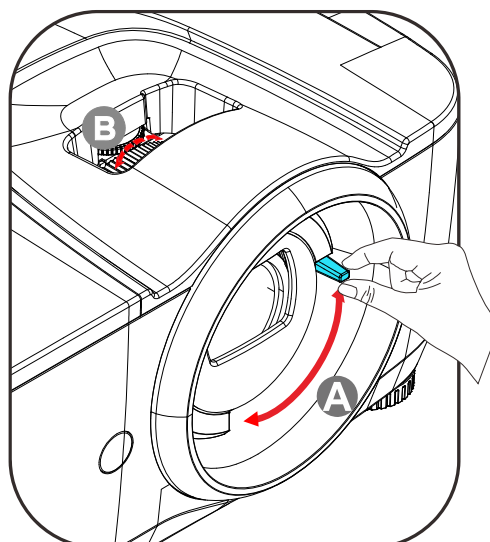

Adjusting the Volume

1. Press the **Volume** buttons on the remote control.
The volume control appears on the display.

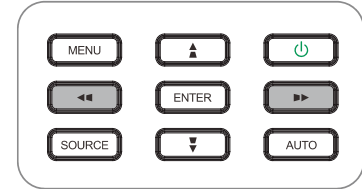
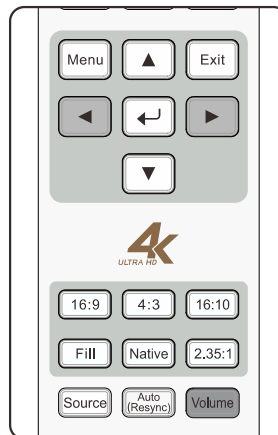

2. Press the ◀▶ buttons on the keypad or remote control to adjust **Volume +/-**



3. Press the **MUTE** button to turn off the volume. (This feature is available only on the remote).



ON-SCREEN DISPLAY (OSD) MENU SETTINGS

OSD Menu Controls

The projector has an OSD that lets you make image adjustments and change various settings.

Navigating the OSD

You can use the remote control cursor buttons or the buttons on the projector to navigate and make changes to the OSD. The following illustration shows the corresponding buttons on the projector.

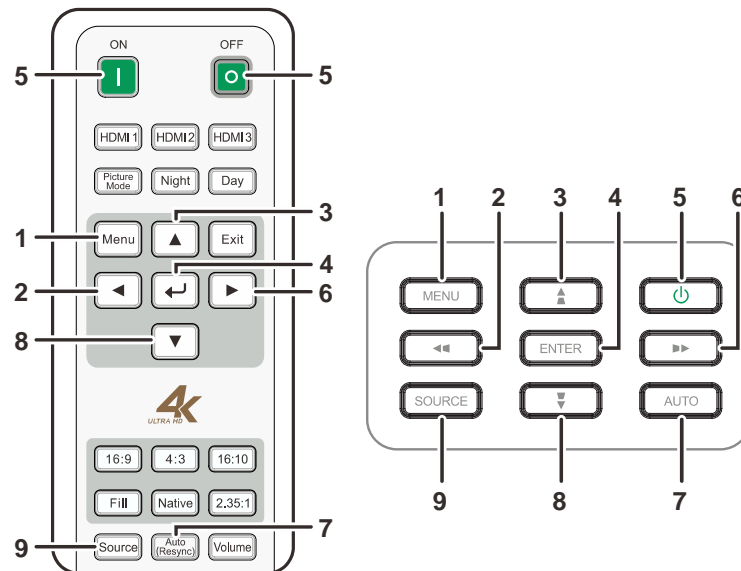

1. To enter the OSD, press the **MENU** button.
2. There are seven menus. Press the cursor **▲▼** button to move through the menus.
3. Press **↵** (Enter) or **▶** button into submenu. Press the cursor **▲▼** button to move up and down in submenu.
4. Select one of the submenu, Press **↵** (Enter) or **▶** button into the selected item. Press **▲▼** or **◀▶** to change values for settings.
5. Press **MENU** to close the OSD or leave a submenu.

Main	
Source	HDMI1
Image	▶
Color	▶
Lamp Control	▶
Setup	▶
Advanced	▶
Information	▶

Setting the OSD Language

Set the OSD language to your preference before continuing.

1. Press the **MENU** button. Press the cursor **▲▼** button to navigate to **Setup**. Press **↵** (Enter) or **▶** to enter the **Setup** submenu.

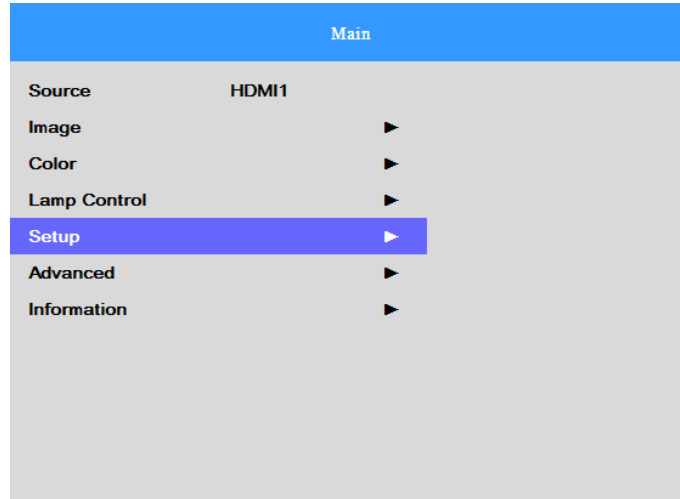

2. Press the cursor **▲▼** button until **MENU Settings** is highlighted. Press **↵** (Enter) or **▶** to enter the **MENU Settings** submenu.

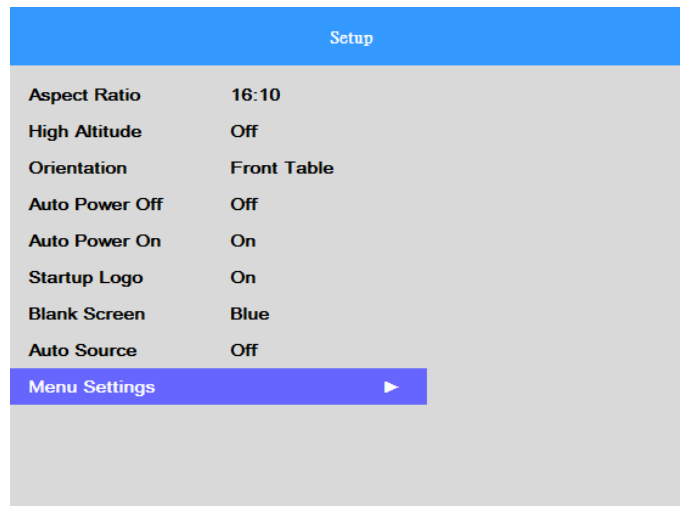

3. Press the cursor **▲▼** button to select **Language** menu. Press **↵** (Enter) to display language. Press the cursor **▲▼** button until the language you want is highlighted.

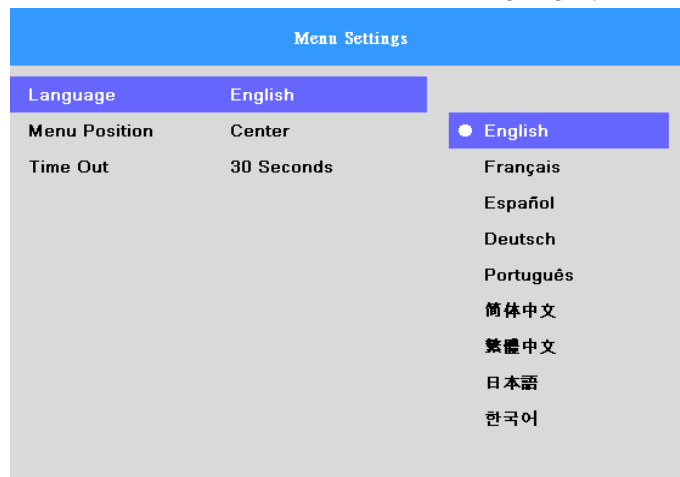

4. Press the **MENU** button twice to close the OSD.

OSD Menu Overview

Use the following illustration to quickly find a setting or determine the range for a setting.

Main Menu	Sub Menu	Settings	
Source		HDMI 1, HDMI 2, HDMI 3	
Image	Picture Mode	Movie, Presentation, Day, Night, User	
	Gamma	1.8, 2.0, 2.2, 2.4, S-curve	
	Brightness	0 ~ 100	
	Contrast	0 - 100	
	Saturation	0 - 100	
	Hue	0 - 100	
	Sharpness	0 - 10	
	Freeze	Off, On	
	Reset	Reset current picture mode	
Color	Color Temperature	Warm, Normal, Cold	
	HSG	Red	Hue, Saturation, Gain 0~199
		Green	Hue, Saturation, Gain 0~199
		Blue	Hue, Saturation, Gain 0~199
		Yellow	Hue, Saturation, Gain 0~199
		Cyan	Hue, Saturation, Gain 0~199
		Magenta	Hue, Saturation, Gain 0~199
		White	Red, Green, Blue 0~199
		Reset	

Main Menu	Sub Menu	Settings	
Lamp Control	Power Mode	Boost, Default	
	Lamp Hour Reset		
Setup	Aspect Ratio	Fill, 4:3, 16:9, 16:10, Native, 2.35:1	
	High Altitude	Off, On	
	Orientation	Front Table, Front Ceiling, Rear Table, Rear Ceiling	
	Auto Power Off	Off, On	
	Auto Power On	Off, On	
	Startup Logo	Off, On	
	Blank Screen	Black, Purple, Blue, White	
	Auto Source	Off, On	
	Menu Settings	Language	English, Français, Español, Deutsch, Português, 簡体中文, 繁體中文, 日本語, 한국어
		Menu Position	Top Left, Top Right, Bottom Left, Bottom Right, Center
Time Out		Always, 10 Seconds, 30 Seconds, 60 Seconds	
Advanced	HDR Control	Auto, Off	
	HDR Settings	Normal, Details, User	
Information	Model Name		
	Software Version 1		
	Software Version 2		
	Software Version 3		
	Active Source		
	Signal Format		
	Lamp Hours		
Reset All			

Main Menu

Press the **MENU** button to open the **Main** menu.

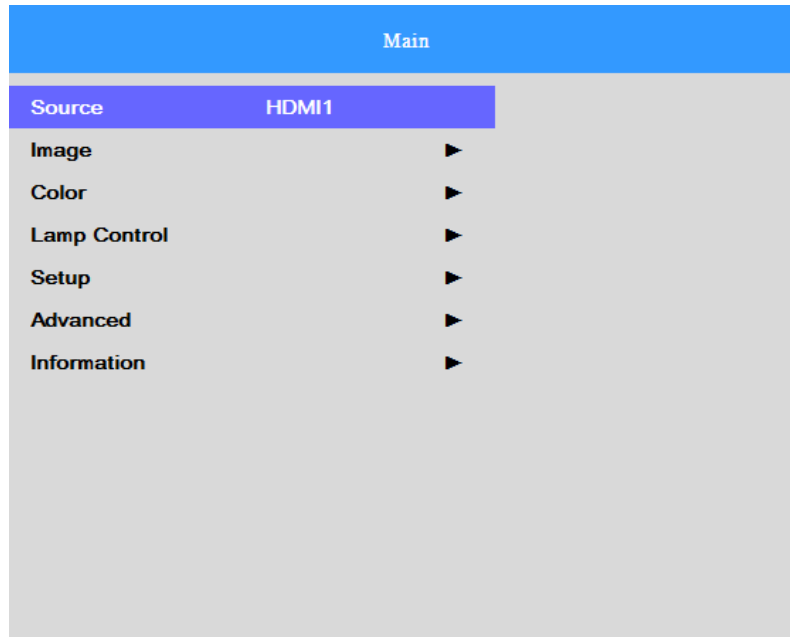

ITEM	DESCRIPTION
Source	Press ↵ (Enter) to enter and select the source.
Image	Press ↵ (Enter) / ▶ to enter the Image sub menu. See Image Settings on page 20.
Color	Press ↵ (Enter) / ▶ to enter the Color sub menu. See Color Settings on page 21.
Lamp Control	Press ↵ (Enter) / ▶ to enter the Lamp Control sub menu. See Lamp Control on page 23.
Setup	Press ↵ (Enter) / ▶ to enter the Setup sub menu. See Setup on page 25.
Advanced	Press ↵ (Enter) / ▶ to enter the Advanced sub menu. See Advanced on page 24.
Information	Press ↵ (Enter) / ▶ to enter the Information sub menu. See Information Menu on page 27.

Image Settings

Press the **MENU** button to open the **OSD** menu. Press the cursor **▲▼** button to move to the **Image** menu. Press **←** (Enter) / **→** to enter the **Image** sub menu. Press **▲▼** button to move up and down in the **Image** item. Press **←** (Enter) / **→** to entry item. Press **▲▼** or **←** **→** to change values for settings.



ITEM	DESCRIPTION
Picture Mode	Press ← (Enter) to enter to set the Picture Mode.
Gamma	Press ← (Enter) to enter and adjust the Gamma correction of the display.
Brightness	Press ← (Enter) / → to enter to adjust the display Brightness.
Contrast	Press ← (Enter) / → to enter to adjust the display Contrast.
Saturation	Press ← (Enter) / → to enter to adjust the Saturation.
Hue	Press ← (Enter) / → to enter to adjust the Hue.
Sharpness	Press ← (Enter) / → to enter to adjust the display sharpness level.
Freeze	Press ← (Enter) to enter and enable or disable the Freeze.
Reset	Press ← (Enter) to reset current picture mode.

Color Settings

Press the **MENU** button to open the **OSD** menu. Press the cursor **▲▼** button to move to the **Color** menu. Press **←** (Enter) / **▶** to enter the **Color** sub menu. Press **▲▼** button to move up and down in the **Color** item. Press **←** (Enter) / **▶** to entry item. Press **▲▼** to change values for settings.



ITEM	DESCRIPTION
Color Temperature	Press ← (Enter) to enter to set the Color Temperature.
HSG	Press ← (Enter) / ▶ to enter the HSG (Hue/Saturation/Gain) sub menu. See SG Adjustment on page 22

HSG Adjustment

Press the **↵** (Enter) / **▶** button to enter the **HSG Adjustment** sub menu. Press **▲ ▼** button to move up and down in the **HSG** item. Press **↵** (Enter) / **▶** to entry item. Press **▲ ▼** to change values for settings.



ITEM	DESCRIPTION
Red	Select to enter the Red Color Manager. Press ↵ (Enter) / ▶ to enter and to adjust the Hue, Saturation, and Gain.
Green	Select to enter the Green Color Manager. Press ↵ (Enter) / ▶ to enter and to adjust the Hue, Saturation, and Gain.
Blue	Select to enter the Blue Color Manager. Press ↵ (Enter) / ▶ to enter and to adjust the Hue, Saturation, and Gain.
Yellow	Select to enter the Yellow Color Manager. Press ↵ (Enter) / ▶ to enter and to adjust the Hue, Saturation, and Gain.
Cyan	Select to enter the Cyan Color Manager. Press ↵ (Enter) / ▶ to enter and to adjust the Hue, Saturation, and Gain.
Magenta	Select to enter the Magenta Color Manager. Press ↵ (Enter) / ▶ to enter and to adjust the Hue, Saturation, and Gain.
White	Select to enter the White Color Manager. Press ↵ (Enter) / ▶ to enter and to adjust the Red, Green, and Blue.
Reset	Press ↵ (Enter) to execute and HSG will be reset to default values

Lamp Control

Press the **MENU** button to open the **OSD** menu. Press the cursor **▲▼** button to move to the **Lamp Control** menu. Press **←** (Enter) / **→** to enter the **Lamp Control** sub menu. Press **▲▼** button to move up and down in the **Lamp Control** item. Press **←** (Enter) / **→** to entry item. Press **▲▼** to change values for settings.

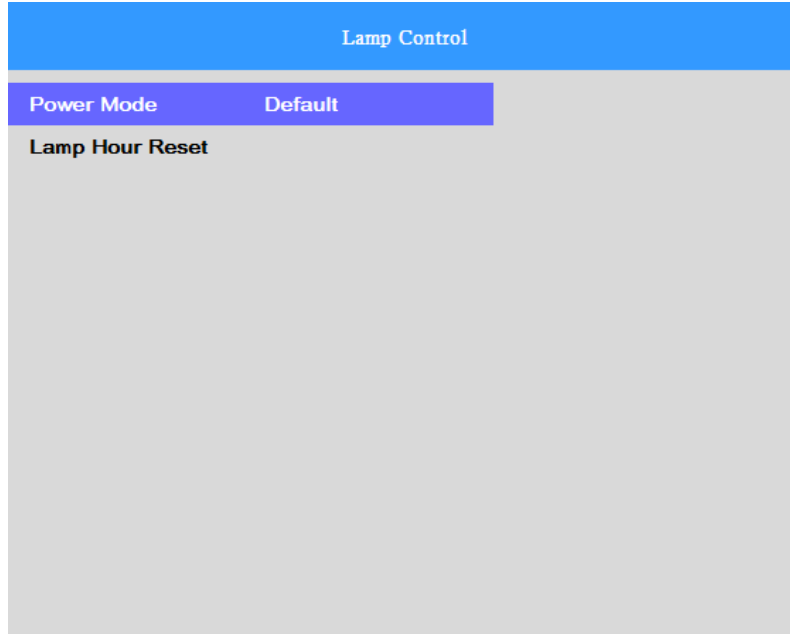

ITEM	DESCRIPTION
Power Mode	Press ← (Enter) to enter and select the Power mode for higher brightness or lower brightness to save lamp life.
Lamp Hour Reset	After replacing the lamp, this item should be reset. See page 31 for more information on Resetting the Lamp .

Setup

Press the **MENU** button to open the **OSD** menu. Press the cursor **▲▼** button to move to the **Setup** menu. Press **←** (Enter) / **▶** to enter the **Setup** sub menu. Press **▲▼** button to move up and down in the **Setup** item. Press **←** (Enter) / **▶** to entry item. Press **▲▼** to change values for settings.

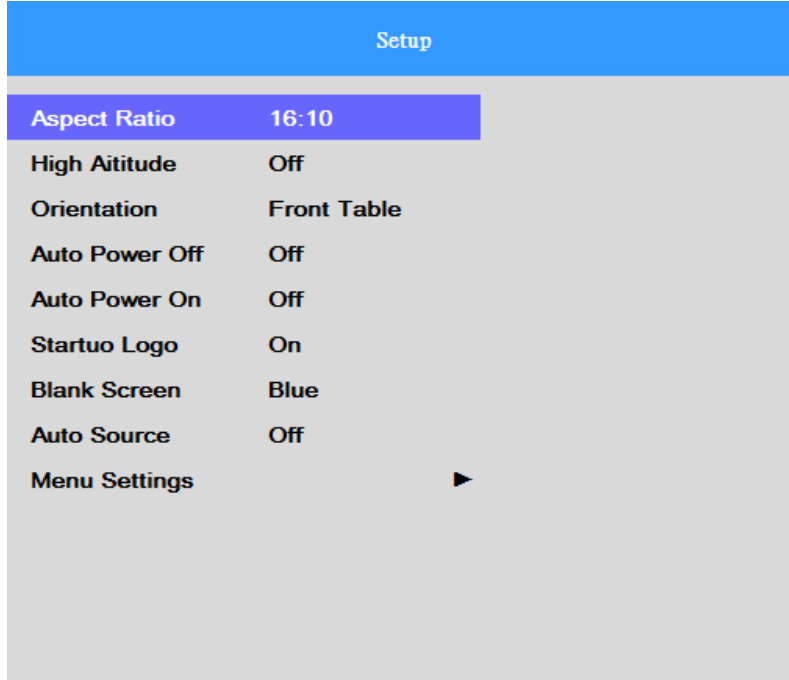

ITEM	DESCRIPTION
Aspect Ratio	Press ← (Enter) to enter and adjust the video aspect ratio.
High Altitude	Press ← (Enter) to enter and select the High Altitude mode On or Off. Note: Recommend selecting high speed when the altitude of the environment is higher than 1500m (4921ft).
Orientation	Press ← (Enter) to enter and select different projection style for projector.
Auto Power Off	Press ← (Enter) to enter to set the Auto Power Off timer. The projector automatically turns off if no input source is detected after the preset period of time.
Auto Power On	Press ← (Enter) to enter and enable or disable automatic power On when AC power is supplied.
Startup Logo	Press ← (Enter) to enter and enable or disable Startup Logo
Blank Screen	Press ← (Enter) to select different color to blank the screen.
Auto Source	Press ← (Enter) to enter and enable or disable automatic source detection.
Menu Settings	Press ← (Enter) / ▶ to enter the Menu Settings sub menu. See Menu Settings on page 29.

Menu Settings

Press the **←** (Enter) / **▶** button to enter the **Menu Settings** sub menu. Press **▲** **▼** button to move up and down in the **Menu Settings** item. Press **←** (Enter) / **▶** to entry item. Press **▲** **▼** to change values for settings.



ITEM	DESCRIPTION
Language	Press ← (Enter) to enter to select a different localization Menu.
Menu Position	Press ← (Enter) to enter to select a different OSD location.
Time Out	Press ← (Enter) to enter to select OSD timeout delay.

Advanced

Press the **MENU** button to open the **OSD** menu. Press the cursor **▲▼** button to move to the **Advanced** menu. Press **←** (Enter) / **→** to enter the **Advanced** sub menu. Press **▲▼** button to move up and down in the **Advanced** item. Press **←** (Enter) / **→** to entry item. Press **▲▼** to change values for settings.

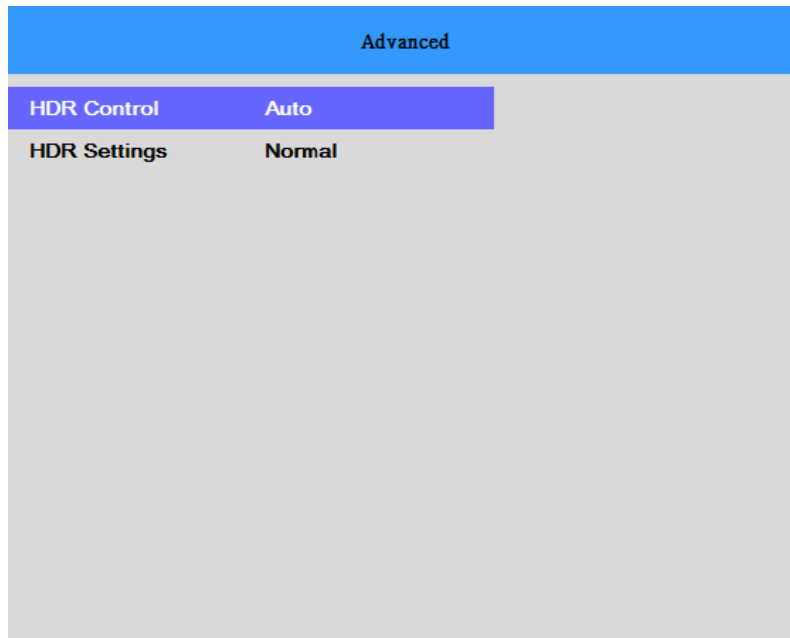

ITEM	DESCRIPTION
HDR Control	Press ← (Enter) to enter and enable or disable HDR Control.
HDR Settings	Press ← (Enter) to enter and select the HDR effect settings.

Information Menu

Press the **MENU** button to open the **OSD** menu. Press the cursor **▲▼** button to move to the **Information** menu. Press **←** (Enter) / **→** to enter the **Information** sub menu. Press **▲▼** button to move up and down in the **Information** item.

Information	
Model Name	HK2288
Software Version 1	MS006c
Software Version 2	D003
Software Version 3	MC01
Active Source	HDMI1
Signal Format	3840x2160@60Hz
Lamp Hours	(97,0)
Reset All	

ITEM	DESCRIPTION
Model Name	Displays the activated input source.
Software Version 1	Showing system software version.
Software Version 2	Showing system software version.
Software Version 3	Showing system software version.
Active Source	Displays the activated source.
Signal Format	Showing the Timing of the Projector.
Lamp Hours	Displays the number of hours the lamp has been in use.
Reset All	Press ← (Enter) to reset all settings to default values.

Note:

Status displayed in this menu is for viewing only and cannot be edited.

MAINTENANCE AND SECURITY

Replacing the Projection Lamp

The projection lamp should be replaced when it burns out. It should only be replaced with a certified replacement part, which you can order from your local dealer.



Important:

- a. The projection lamp used in this product contains a small amount of mercury.
- b. Do not dispose this product with general household waste.
- c. Disposal of this product must be carried out in accordance with the regulations of your local authority.



Warning:

Be sure to turn off and unplug the projector at least 30 minutes before replacing the lamp. Failure to do so could result in a severe burn.



Caution:

In rare cases the lamp bulb may burn out during normal operation and cause glass dust or shards to be discharged outward from the rear exhaust vent.

Do not inhale or do not touch glass dust or shards. Doing so could result in injury.

Always keep your face away from the exhaust vent so that you do not suffer from the gas and broken shards of the lamp.

When removing the lamp from a ceiling-mounted projector, make sure that no one is under the projector. Glass fragments could fall if the lamp has been burned out.



IF A LAMP EXPLODES

If a lamp explodes, the gas and broken shards may scatter inside the projector and they may come out of the exhaust vent. The gas contains toxic mercury.

Open windows and doors for ventilation.

If you inhale the gas or the shards of the broken lamp enter your eyes or mouth, consult the doctor immediately.

1. Loosen the two screws on the lamp compartment cover.

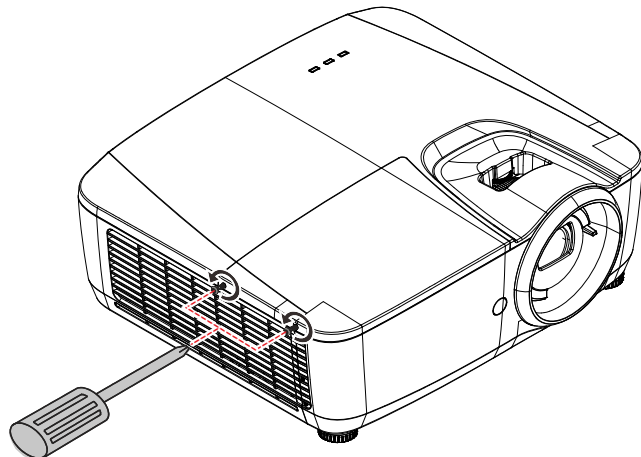

- 2.** Remove the lamp compartment cover.

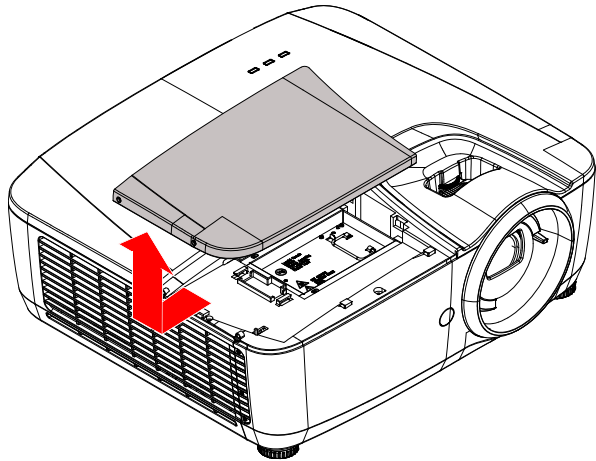

- 3.** Remove the three screws from the lamp module.

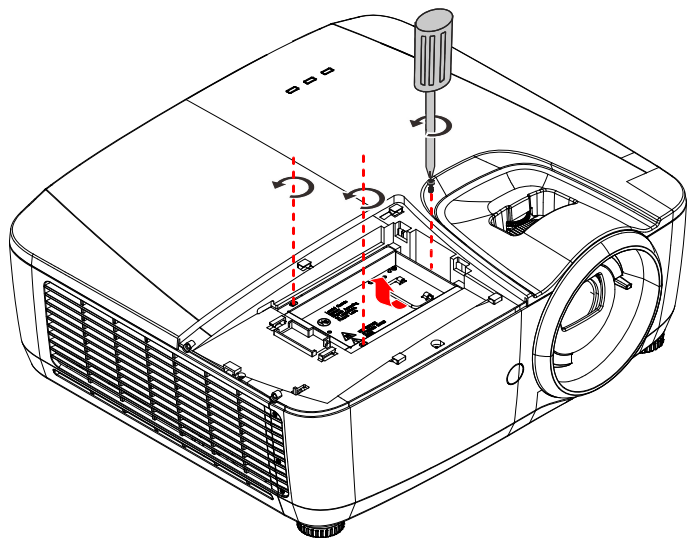

- 4.** Lift the module handle up.

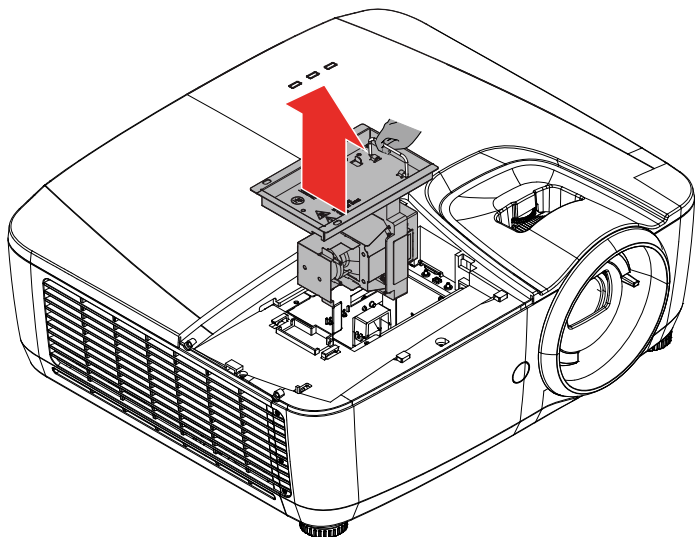

- 5.** Pull firmly on the module handle to remove the lamp module.

- 6.** Reverse steps 1 to 5 to install the new lamp module. While installing, align the lamp module with the connector and ensure it is level to avoid damage.

Note:

The lamp module must sit securely in place and the lamp connector must be connected properly before tightening the screws.

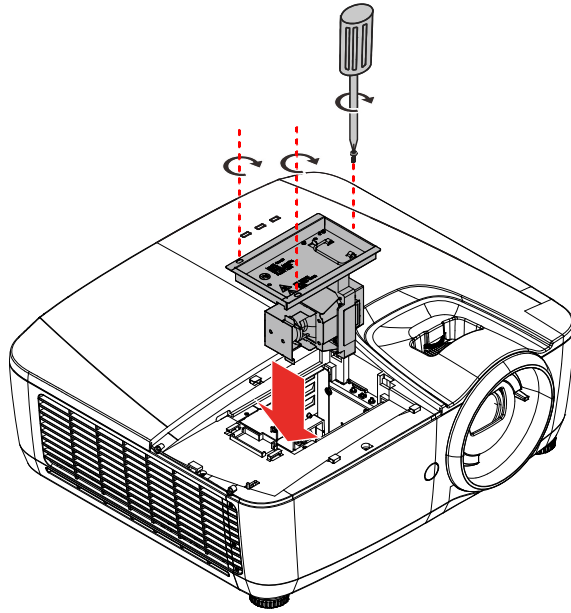

Resetting the Lamp

After replacing the lamp, you should reset the lamp hour counter to zero. Refer to the following:

1. Press the **MENU** button to open the OSD menu.
2. Press the cursor **▼▲** button to move to the **Lamp Control** menu. Press **←** (Enter) / **▶** to enter the **Lamp Control** sub menu.
3. Press the cursor **▼▲** button to move down to **Lamp Hour Reset**.
4. Press **←** (Enter) to adjust the settings.
5. Press the **MENU** button to get back to **Lamp Control**.

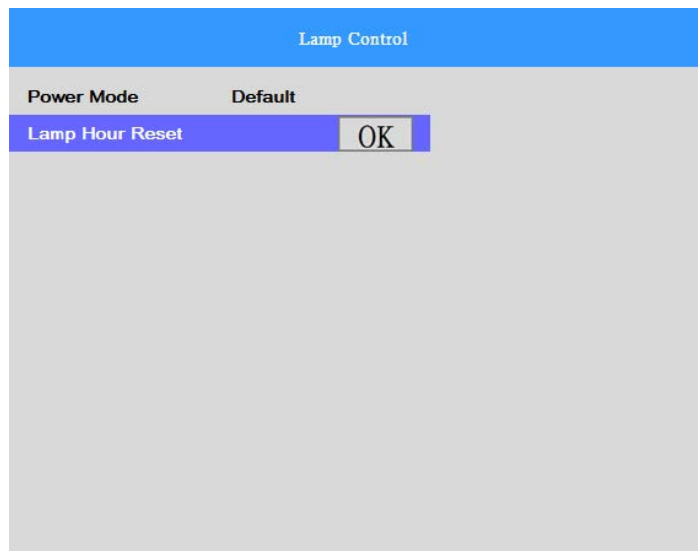
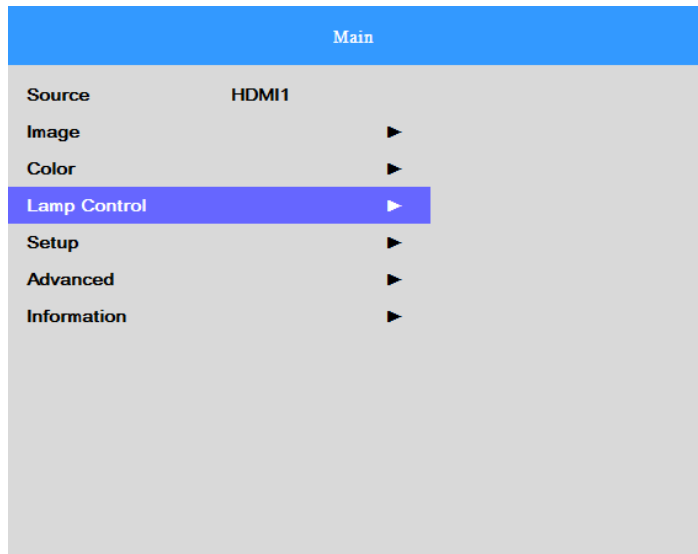

Cleaning the Projector

Cleaning the projector to remove dust and grime will help ensure trouble-free operation.



Warning:

1. *Be sure to turn off and unplug the projector at least 30 minutes before cleaning. Failure to do so could result in a severe burn.*
2. *Use only a dampened cloth when cleaning. Do not allow water to enter the ventilation openings on the projector.*
3. *If a little water gets into the projector interior while cleaning, leave unplugged in a well-ventilated room for several hours before using.*
4. *If a lot of water gets into the projector interior when cleaning, have the projector serviced.*

Cleaning the Lens

You can purchase optic lens cleaner from most camera stores. Refer to the following to clean the projector lens.

1. Apply a little optic lens cleaner to a clean soft cloth. (Do not apply the cleaner directly to the lens.)
2. Lightly wipe the lens in a circular motion.



Caution:

1. *Do not use abrasive cleaners or solvents.*
2. *To prevent discoloration or fading, avoid getting cleaner on the projector case.*

Cleaning the Case

Refer to the following to clean the projector case.

1. Wipe off dust with a clean dampened cloth.
2. Moisten the cloth with warm water and mild detergent (such as used to wash dishes), and then wipe the case.
3. Rinse all detergent from the cloth and wipe the projector again.



Caution:

To prevent discoloration or fading of the case, do not use abrasive alcohol-based cleaners.

Using the Physical Lock

Using the Security Bar

In addition to the password protection function and the Kensington lock, the Security Bar helps protect the projector from unauthorized removal. See the following picture.

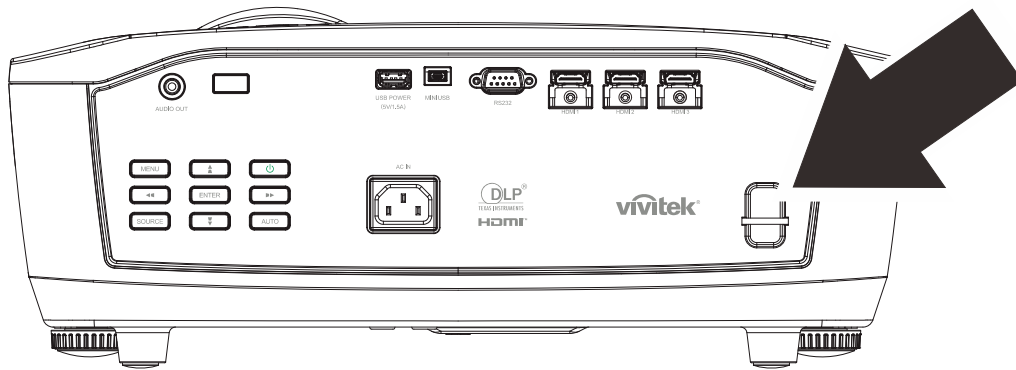

Common problems and solutions

These guidelines provide tips to deal with problems you may encounter while using the projector. If the problem remains unsolved, contact your dealer for assistance.

Often after time spent troubleshooting, the problem is traced to something as simple as a loose connection. Check the following before proceeding to the problem-specific solutions.

- *Use some other electrical device to confirm that the electrical outlet is working.*
- *Ensure the projector is turned on.*
- *Ensure all connections are securely attached.*
- *Ensure the attached device is turned on.*
- *Ensure a connected PC is not in suspending mode.*
- *Ensure a connected notebook computer is configured for an external display. (This is usually done by pressing an Fn-key combination on the notebook.)*

Tips for Troubleshooting

In each problem-specific section, try the steps in the order suggested. This may help you to solve the problem more quickly.

Try to pin point the problem and thus avoid replacing non-defective parts.

For example, if you replace batteries and the problem remains, put the original batteries back and go to the next step.

Keep a record of the steps you take when troubleshooting: The information may be useful when calling for technical support or for passing on to service personnel.

LED Error Messages

ERROR CODE MESSAGES	POWER LED GREEN	TEMP LED RED	LAMP LED RED
Standby	ON	OFF	OFF
Start warm up	Flashing(Green)	OFF	OFF
Lamp Ready	Green	OFF	OFF
Cooling	Flashing(Green)	OFF	OFF
1W MCU detects scaler stops working (initial fail)	2 blinks	OFF	OFF
Over Temperature	OFF	ON	OFF
Thermal Break Sensor error	4 blinks	OFF	OFF
Lamp strike fail / ballast connector open	5 blinks	OFF	OFF
Lamp voltage too low	5 blinks	OFF	7 blinks
Ballast fail	5 blinks	OFF	8 blinks
Ballast communication fail	5 blinks	OFF	10 blinks
Ballast over temp	5 blinks	OFF	1 blinks
Lamp fail	5 blinks	OFF	5 blinks
Fan 1 error	6 blinks	OFF	1 blinks
Fan 2 error	6 blinks	OFF	2 blinks
Fan 3 error	6 blinks	OFF	3 blinks
Fan 4 error	6 blinks	OFF	4 blinks
Fan 5 error	6 blinks	OFF	5 blinks
Case Open	7 blinks	OFF	OFF
DMD error	8 blinks	OFF	OFF
T1 error	OFF	ON	1 blinks
Color wheel error	9 blinks	OFF	OFF
ASIC not ready	8 blinks	OFF	1 blinks
Lamp Blower stops(Not running.)	5 blinks	OFF	6 blinks

In the event of an error, please disconnect the AC power cord and wait for one (1) minute before restarting the projector. If the Power or Lamp LEDs are still blinking or any other situation that isn't listed in the chart above, please contact your service center.

Image Problems

Problem: No image appears on the screen

1. Verify the settings on your notebook or desktop PC.
2. Turn off all equipment and power up again in the correct order.

Problem: The image is blurred

1. Adjust the **Focus** on the projector.
2. Press the **Auto** button on the remote control.
3. Ensure the projector-to-screen distance is within the specified range.
4. Check that the projector lens is clean.

Problem: The image is reversed

Check the **Orientation** setting on the **Setup** menu of the OSD.

Problem: The image is flat with no contrast

Adjust the **Contrast** setting on the **Image** menu of the OSD.

Problem: The color of the projected image does not match the source image.

Adjust the **Color Temperature** and **Gamma** settings on the **Color** and **Image** menu of the OSD.

Lamp Problems

Problem: There is no light from the projector

1. Check that the power cable is securely connected.
2. Ensure the power source is good by testing with another electrical device.
3. Restart the projector in the correct order and check that the Power LED is on.
4. If you have replaced the lamp recently, try resetting the lamp connections.
5. Replace the lamp module.
6. Put the old lamp back in the projector and have the projector serviced.

Problem: The lamp goes off

1. Power surges can cause the lamp to turn off. Re-plug power cord. When the Power LED is on, press the power button.
2. Replace the lamp module.
3. Put the old lamp back in the projector and have the projector serviced.

Remote Control Problems

Problem: The projector does not respond to the remote control

1. Direct the remote control towards remote sensor on the projector.
2. Ensure the path between remote and sensor is not obstructed.
3. Turn off any fluorescent lights in the room.
4. Check the battery polarity.
5. Replace the battery.
6. Turn off other Infrared-enabled devices in the vicinity.
7. Have the remote control serviced.

Audio Problems

Problem: There is no sound

1. Adjust the volume on the remote control.
2. Adjust the volume of the audio source.
3. Check the audio cable connection.
4. Test the source audio output with other speakers.
5. Have the projector serviced.

Problem: The sound is distorted

1. Check the audio cable connection.
2. Test the source audio output with other speakers.
3. Have the projector serviced.

Having the Projector Serviced

If you are unable to solve the problem, you should have the projector serviced. Pack the projector in the original carton. Include a description of the problem and a checklist of the steps you took when trying to fix the problem: The information may be useful to service personnel. For servicing, return the projector to the place you purchased it.

HDMI Q & A

Q. What is the difference between a “Standard” HDMI cable and a “High-Speed” HDMI cable?

Recently, HDMI Licensing, LLC announced that cables would be tested as Standard or High-Speed cables.

Standard (or “category 1”) HDMI cables have been tested to perform at speeds of 75Mhz or up to 2.25Gbps, which is the equivalent of a 720p/1080i signal.

High Speed (or “category 2”) HDMI cables have been tested to perform at speeds of 340Mhz or up to 10.2Gbps, which is the highest bandwidth currently available over an HDMI cable and can successfully handle 1080p signals including those at increased color depths and/or increased refresh rates from the Source. High-Speed cables are also able to accommodate higher resolution displays, such as WQXGA cinema monitors (resolution of 2560 x 1600).

Q. How do I run HDMI cables longer than 10 meters?

There are many HDMI Adopters working on HDMI solutions that extend a cable’s effective distance from the typical 10 meter range to much longer lengths. These companies manufacture a variety of solutions that include active cables (active electronics built into cables that boost and extend the cable’s signal), repeaters, amplifiers as well as CAT5/6 and fiber solutions.

Q. How can I tell if a cable is an HDMI certified cable?

All HDMI products are required to be certified by the manufacturer as part of the HDMI Compliance Test Specification. However, there may be instances where cables bearing the HDMI logo are available but have not been properly tested. HDMI Licensing, LLC actively investigates these instances to ensure that the HDMI trademark is properly used in the market. We recommend that consumers buy their cables from a reputable source and a company that is trusted.

For more detail information check <http://www.hdmi.org/learningcenter/faq.aspx#49>

SPECIFICATIONS

Specifications

Model	HK2288
Display Type	0.66" TRP UHD
Resolution	3840 x 2160
Projection Distance	1.2 ~ 10 m
Projection Screen Size	26.0" ~ 324.9"
Projection Lens	Manual Focus/Manual Zoom
Throw Ratio	1.39~2.09
Projection Methods	Front, Rear, Desktop/Ceiling (Rear, Front)
Data Compatibility	VGA, SVGA, XGA, WXGA, SXGA, SXGA+, UXGA, WUXGA, Mac
SDTV/EDTV/ HDTV	480i, 480p, 720p, 1080i, 1080p, UHD
Safety Certification	UL/CUL, FCC, CB/CE, CCC, PCT, PSB, KC+KCC, SASO
Operation Temperature	5° ~ 40°C
Environmental Storage Condition	-10° ~ 60°C, 5% to 95% (No condensation)
Dimensions	427.2 mm (W) x 379.7 mm (D) x 172.1 mm (H)
Ac Input	AC Universal 100-240V
Power Consumption	450W (Normal), <0.5W (Standby)
Lamp	310W
Audio Speaker	7W x1 (10W peak)
Input Terminals	HDMI x 3
Output Terminals	PC Audio jack(3.5mm) x 1
Control Terminals	RS-232C
	USB (Type mini B) - service only
	USB (type A) support DC 5V
Security	Security Bar

Note: For questions regarding product specifications, please contact your local distributor.

Projection Distance vs. Projection Size

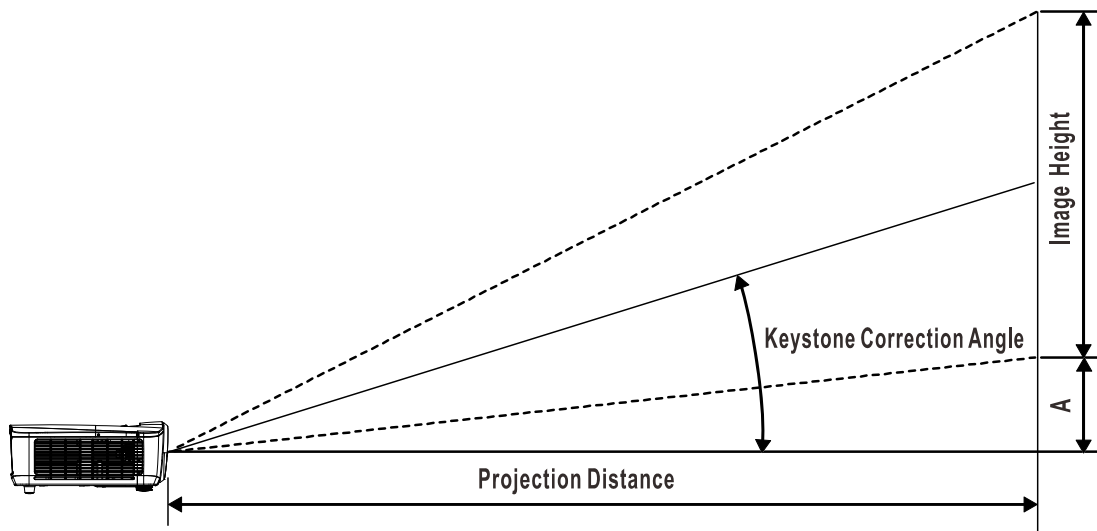

Projection Distance and Size Table

HK2288									
IMAGE DIAGONAL	IMAGE WIDTH		IMAGE HEIGHT		PROJECTION DISTANCE FROM		PROJECTION DISTANCE TO		OFFSET-A
	(INCH)	(CM)	(INCH)	(CM)	(INCH)	(CM)	(INCH)	(CM)	
60	52.3	132.8	29.4	74.7	72.7	184.6	109.3	277.6	0.0
70	61.0	155.0	34.3	87.2	84.8	215.4	127.5	323.9	0.0
72	62.8	159.4	35.3	89.7	87.2	221.5	131.1	333.1	0.0
80	69.7	177.1	39.2	99.6	96.9	246.2	145.7	370.1	0.0
84	73.2	186.0	41.2	104.6	101.8	258.5	153.0	388.6	0.0
90	78.4	199.2	44.1	112.1	109.0	276.9	163.9	416.4	0.0
96	83.7	212.5	47.1	119.6	116.3	295.4	174.9	444.2	0.0
100	87.2	221.4	49.0	124.5	121.1	307.7	182.2	462.7	0.0
120	104.6	265.6	58.8	149.5	145.4	369.2	218.6	555.2	0.0
135	117.7	298.9	66.2	168.1	163.5	415.4	245.9	624.6	0.0
150	130.7	332.1	73.5	186.8	181.7	461.6	273.2	694.0	0.0
200	174.3	442.7	98.1	249.1	242.3	615.4	364.3	925.3	0.0

Timing Mode Table

Signal Format	Resolution	Frame Rate HZ	HDMI1 /HDMI2 /HDMI3			
			RGB	8-bit YUV	10-bit YUV	12-bit YUV
PC	640x480	59.94	○	—	—	—
	640x480	74.99	○	—	—	—
	640x480	85	○	—	—	—
	800x600	60.32	○	—	—	—
	800x600	75	○	—	—	—
	800x600	85.06	○	—	—	—
	848x480	47.95	○	—	—	—
	848x480	59.94	○	—	—	—
	1024*768	60	○	—	—	—
	1024*768	75	○	—	—	—
	1024*768	85	○	—	—	—
	1280x720	47.95	○	—	—	—
	1280x1024	60.02	○	—	—	—
	1280x1024	75.02	○	—	—	—
	1280x1024	85.02	○	—	—	—
	1600x1200	60	○	—	—	—
	1920x1080	47.95	○	—	—	—
	1680x1050	59.94	○	—	—	—
	1920x1200 RB	50	○	—	—	—
	1920x1200 RB	60	○	—	—	—
	1400X1050	60	○	—	—	—
	1366 x 768	60	○	—	—	—
	1440 x 900	60	○	—	—	—
	1280 x 768	60	○	—	—	—
1280 x 800	60	○	—	—	—	
1280 x 960	60	○	—	—	—	
Apple Mac	640x480	66.59	○	—	—	—
	832x624	74.54	○	—	—	—
SDTV	480i	59.94	—	—	—	—
	1440x480i	60	○	○	○	○
	1440x576i	50	○	○	○	○
	576i	50	—	—	—	—
EDTV	480p	59.94	○	○	○	○
	576p	50	○	○	○	○

Signal Format	Resolution	Frame Rate HZ	HDMI1 /HDMI2 /HDMI3			
			RGB	8-bit YUV	10-bit YUV	12-bit YUV
HDTV	1035i	60	○	○	○	○
	1080i	50	○	○	○	○
	1080i	59.94	○	○	○	○
	1080i	60	○	○	○	○
	720p	50	○	○	○	○
	720p	59.94	○	○	○	○
	720p	60	○	○	○	○
	1080p	23.98	○	○	○	○
	1080p	24	○	○	○	○
	1080p	25	○	○	○	○
	1080p	29.97	○	○	○	○
	1080p	30	○	○	○	○
	1080p	50	○	○	○	○
	1080p	59.94	○	○	○	○
	1080p	60	○	○	○	○
	2K	24/25/30/50/60	○	○	○	○
	4K	24/25/30	○	○	○	○
	4K	50/60	○(8 Bits)	○	○(4:2:2)	○(4:2:2)
PsF formats	1080sf	30	—	—	—	—
	1080sf	25	—	—	—	—

○ : Frequency supported

— : Frequency not supported

★3840x2160 did not supported 3D function and timing.

Projector Dimensions

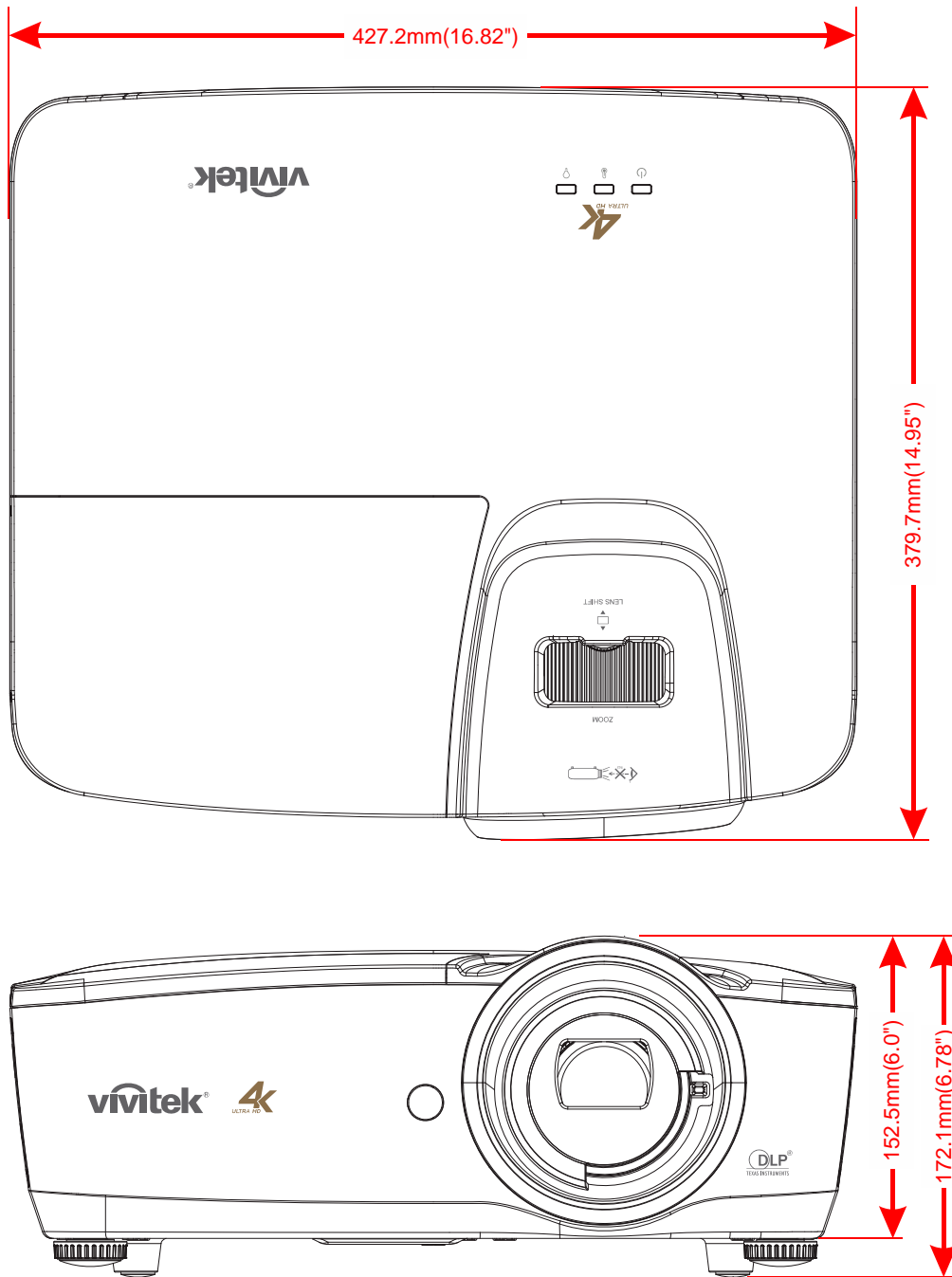

REGULATORY COMPLIANCE

FCC Warning

This equipment has been tested and found to comply with the limits for a Class B digital device pursuant to Part 15 of the FCC Rules. These limits are designed to provide reasonable protection against harmful interference when the equipment is operated in a commercial environment.

This equipment generates, uses, and can radiate radio frequency energy and, if not installed and used in accordance with the instruction manual, may cause harmful interference to radio communications. Operation of this equipment in a residential area is likely to cause harmful interference in which case the user will be required to correct the interference at his/her own expense.

Changes or modifications not expressly approved by the parties responsible for compliance could void the user's authority to operate the equipment.

Canada

This class B digital apparatus complies with Canadian ICES-003.

Safety Certifications

UL/CUL, FCC, CB/CE, CCC, PCT, PSB, KC+KCC, NOM, SASO

OP Command

The RS-232 Commands use only ASCII characters which can be entered using a typical terminal emulator like Windows HyperTerminal with the following setting:

RS232 Setting	
Baud rate:	9600
Parity check:	None
Data bit:	8
Stop bit:	1
Flow Control	None

Note : that each input character will be echoed on the terminal by system and there is no need to set the local echo “ON” with the terminal setting.

Note : that “Unknown Command” is echoed on the terminal by system when system state is stand by and low power mode is “ON” if the input command is other than “op power.on [CR]”/ “op status [CR]”.

System Operation commands.

The Operation commands tell the projector what to do. All commands start with 2 letters: “op” for operations commands, and a space [SP] then following a control command then finally the value wants to read, set, increase or decrease. All commands must end with a carriage return (ASCII hex 0D), shown as [CR] below. The syntax for operations commands is as follows:

op[SP]<operation command>[SP]<Setting Value>[CR]

For all but Execute functions the response from the projector will be the command and “= <value>” where <value> is the current value or “NA” if the value is not available. For Execute functions the response will be the same command. All responses will be in CAPS. Please refer to the following table for command list and examples:

System Operation command:

Operation	Commands	Values
Set	= <value>	Makes the unit take that value.
Get	?	Asks what the current value is.
Execute	(none)	Performs an action such as a reset.

Get operations command example:

Input: **op brightness ? [CR]**

System Response: **OP BRIGHTNESS = 50**

Set operations command example:

Input: **op brightness = 100 [CR]**

System Response: **OP BRIGHTNESS = 100**

Execute command example:

Input: **op pict.reset [CR]**

System Response: **OP PICT.RESET**

Operation	Commands	Values	Notes
source	= ?	0 = HDMI1 1 = HDMI2 2 = HDMI3	Note4
pict.mode	= ?	0 = Movie 1 = Presentation 2 = Day 3 = Night 4 = User	Note1,Note4
brightness	= ?	0 - 100	Note1,Note4
contrast	= ?	0 - 100	Note1,Note4
gamma	= ?	0 = 1.8 1 = 2.0 2 = 2.2 3 = 2.4 4 = S-curve	Note1,Note4
saturation	= ?	0 - 100	Note1,Note4
hue	= ?	0 - 100	Note1,Note4
sharpness	= ?	0 - 10	Note1,Note4
freeze	= ?	0 = Off 1 = On	Note1,Note4
pict.reset	(execute)		Note1,Note4 Reset current picture mode parameters to default value.
color.temp	= ?	0 = Warm 1 = Normal 2 = Cold	Note1,Note4
hsg.hue.r	= ?	0 - 199	Note1,Note4
hsg.hue.g	= ?	0 - 199	Note1,Note4
hsg.hue.b	= ?	0 - 199	Note1,Note4
hsg.hue.c	= ?	0 - 199	Note1,Note4
hsg.hue.m	= ?	0 - 199	Note1,Note4
hsg.hue.y	= ?	0 - 199	Note1,Note4
hsg.sat.r	= ?	0 - 199	Note1,Note4
hsg.sat.g	= ?	0 - 199	Note1,Note4
hsg.sat.b	= ?	0 - 199	Note1,Note4
hsg.sat.c	= ?	0 - 199	Note1,Note4
hsg.sat.m	= ?	0 - 199	Note1,Note4
hsg.sat.y	= ?	0 - 199	Note1,Note4
hsg.gain.r	= ?	0 - 199	Note1,Note4
hsg.gain.g	= ?	0 - 199	Note1,Note4
hsg.gain.b	= ?	0 - 199	Note1,Note4
hsg.gain.c	= ?	0 - 199	Note1,Note4
hsg.gain.m	= ?	0 - 199	Note1,Note4
hsg.gain.y	= ?	0 - 199	Note1,Note4
hsg.white.r	= ?	0 - 199	Note1,Note4
hsg.white.g	= ?	0 - 199	Note1,Note4
hsg.white.b	= ?	0 - 199	Note1,Note4
hsg.reset	(execute)		Note1,Note4
lamp.mode	= ?	0 = Boost 1 = Default	Note2,Note4
lamp.hour.reset	(execute)		Note4 Clear User Lamp Hours (Include Boost/Default hours) (Not includes System Total Hours).

Operation	Commands	Values	Notes
aspect.ratio	= ?	0 = Fill 1 = 4:3 2 = 16:9 3 = 16:10 4 = Native 5 = 2.35:1	Note1,Note4
high.altitude	= ?	1 = On 0 = Off	Note4
orientation	= ?	0 = Front Table 1 = Front Ceiling 2 = Rear Table 3 = Rear Ceiling	Note4
auto.poweroff	= ?	0 = Off 1 = On	Note4
auto.poweron	= ?	0 = Off 1 = On	Note4
auto.source	= ?	0 = Off 1 = On	Note4
startup.logo	= ?	0 = Off 1 = On	Note4
blank.screen	= ?	0 = Black 1 = Purple 2 = Blue 3 = White	Note3,Note4
menu.settings.lang	= ?	0 = English 1 = French 2 = Spanish 3 = German 4 = Portuguese 5 = Chinese Simplified 6 = Chinese Traditional 7 = Japanese 8 = Korean	
menu.settings.menupos	= ?	0 = Top Left 1 = Top Right 2 = Bottom Left 3 = Bottom Right 4 = Center	Note4
menu.settings.timer	= ?	0 = Always On 1 = 10 Seconds 2 = 30 Seconds 3 = 60 Seconds	Note4
hdr.control	= ?	0 = Auto 1 = Off	Note1,Note4
hdr.settings	= ?	0 = Normal 1 = Details 2 = User	Note1,Note4
model.name	?	<string>	Note4
sw.version1	?	<string>	Note4
sw.version2	?	<string>	Note4
sw.version3	?	<string>	Note4
act.source	?		Note4
signal	?	<string>	Note1,Note4
lamp.hours	?	<number>	Note4
reset.all	(execute)		Note4

Operation	Commands	Values	Notes
power.on	(execute)		
power.off	(execute)		Note4
power	= ?	0 = Off 1 = On	Note4

Note1 : Not support when no input source.

Note2 : Not support in 3 min after system power on.

Note3 : Not support when input source is locked and image presents.(But Still adjustable.)

Note4 : Not support when system has already powered on and splash logo finished.